

# Unbalanced Power in Four-Wire Systems and its Reactive Compensation

Leszek S. Czarnecki, Life Fellow, IEEE, Paul M. Haley, Student Member, IEEE

**Abstract** – Unbalanced power of three-phase stationary linear loads with neutral conductor, supplied with sinusoidal symmetrical voltages and its reactive compensation is the subject of the paper. A novel power equation of such loads is developed. The suggested power equation is based on decomposition of the load current into Current Physical Components (CPC). The paper shows that all powers can be expressed in terms of the load parameters and this creates fundamentals for design of balancing reactive compensators capable of improving the power factor to unity. A reactive balancing compensator is composed, in general, of two compensators in  $\Delta$  and Y configuration. The paper presents a method of calculation of LC parameters of such a compensator using the CPC – based power theory.

**Index terms** – Power definitions, power theory, Currents’ Physical Components, CPC.

## I. INTRODUCTION

Loads in residential grids and in commercial buildings are mainly single-phase loads supplied from a three-phase transformer in  $\Delta/Y$  configuration, as shown in Fig. 1, with a grounded neutral conductor.

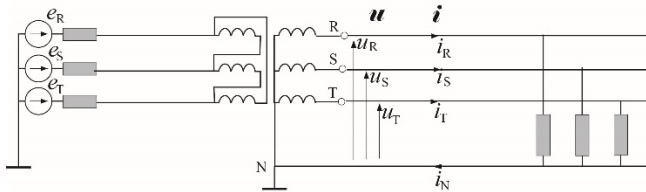

Fig. 1. Stationary single-phase loads supplied from three-phase line with neutral.

Some level of imbalance is a common property of such loads. This imbalance could be particularly visible in traction grids. Such loads are generally nonlinear and time-invariant, thus generating harmonics, but can be regarded at the lowest level of approximation as stationary linear, time-invariant (LTI) loads. Although powers in three-phase systems with nonsinusoidal voltages and currents are the subject of continuous concern and studies [1-6], there is still substantial confusion on powers in systems with unbalanced loads even if voltages and currents are sinusoidal and the supply voltages are symmetrical. Therefore, the subject of this paper is confined just to such a situation, meaning to powers and reactive compensation in four-wire linear systems with sinusoidal and symmetrical supply voltage.

The load imbalance causes the load current asymmetry, thus apart from the current symmetrical component of the positive sequence, the load current may contain also components of the zero and the negative sequence. It causes an increase in energy loss on both sides of the transformer, which may require an increase of its power rating [7].

Compensation of the zero sequence component of the load current can be done only by a compensator installed on the transformer secondary side. This can be accompanied with compensation of the negative sequence component of the secondary current, meaning with load balancing. This enables reduction of energy loss and required power rating of the transformer. Compensation of the load imbalance is usually combined with the reactive power compensation.

Compensators can be built as PWM-based switching compensators (SC), known as ‘active power filters’, or ‘power conditioners’, as reactive compensators (RC), or as hybrid devices, composed of both of them.

There is a huge selection of literature on switching compensators and on control of these devices using various approaches to power theory, to mention only a few of them [8-12]. Much less was published on reactive compensators, in particular, on reactive balancing compensators.

High power transistors, digital data acquisition and digital signal processing (DSP) systems, developed mainly in the last two decades, are needed for SCs construction. Components of RCs, meaning inductors and capacitors, belong to the same class of circuit elements from which stationary three-phase systems, as that shown in Fig. 1, are built. The technology needed for reactive compensators construction has been available incomparably longer than that needed for SCs. In spite of that, the state of the development of reactive compensator technology is lagging behind the technology of switching compensators.

Switching compensators have a number of advantages over reactive compensators. The most important is the fact that they can be easily operated as adaptive devices, while this is not so easy in the case of reactive compensators. On the other side, power constraints for reactive compensators are not as tough as that for switching compensators. A lag in the development of the power theory of three-phase systems can be blamed for a lag in the development of the reactive compensators technology.

Control of SCs does not require any advanced knowledge of power properties of three-phase systems. It is enough to generate a reference signal proportional to an undesirable component of the load current. In the case of RCs design it has to be known how compensated currents depend on the circuit parameters.

Although in 1920 Lyon concluded [14] that the load imbalance reduces the power factor, quantitative effects of the load imbalance upon the apparent power were not known for a long time. Substantial confusion on how the apparent power  $S$  for three-phase systems should be defined was the main reason for that. Two options of definitions were suggested in [15] and discussed in [17], namely

$$S = S_A = U_R I_R + U_S I_S + U_T I_T \tag{1}$$

referred to as *arithmetical apparent power* and

$$S = S_G = \sqrt{P^2 + Q^2} \tag{2}$$

referred to as *geometrical apparent power*.

Buchholz in [16] suggested a different definition, namely

$$S = S_B = \sqrt{U_R^2 + U_S^2 + U_T^2} \sqrt{I_R^2 + I_S^2 + I_T^2}. \quad (3)$$

At symmetrical voltages and currents these three definitions are numerically equivalent. When the load is unbalanced and consequently, the supply currents are asymmetrical, these three definitions provide different values of the apparent power and hence, different values of the power factor,  $\lambda = P/S$ .

The energy loss in a source that supplies unbalanced load and its power factor were studied in [18]. It was found that with respect to loss of energy at its delivery, the power factor  $\lambda$  had a right value only if the apparent power  $S$  was calculated according to the Buchholz definition (3).

The idea of reactive compensation is very old; the first balancing compensator was developed by Steinmetz and presented [13] in 1917. Research on reactive compensation was continued with results reported in several papers, such as [19–29].

There are a number of different approaches to reactive balancing compensator design. It could be based, as in the case of Steinmetz [13], on searching for a circuit that would eliminate the oscillating component of the instantaneous power or by compensation of the negative and zero sequence symmetrical components of the load current. Even optimization methods, which do not require very detailed knowledge of power properties of electrical systems, can be used for that purpose.

The concept of the “*unbalanced power*” was not used in references cited above. As to the authors’ best knowledge, the unbalanced power occurred in a power equation for the first time in 1988 in paper [30] on powers in systems with nonsinusoidal supply voltage. Studies in that paper were confined only to three-phase, three-wire systems, however.

At the assumption that the supply voltage is symmetrical and sinusoidal, powers in such a system have to satisfy the power equation:

$$S^2 = P^2 + Q^2 + D_u^2 \quad (4)$$

where  $D_u$  denotes the unbalanced power, defined as

$$D_u = A \|\mathbf{u}\|^2. \quad (5)$$

Symbol  $A$  denotes the magnitude of the unbalanced admittance of the load, which is specified in terms of equivalent line-to-line admittances of the load as follows

$$A = A e^{j\psi} = -(\mathbf{Y}_{ST} + \alpha \mathbf{Y}_{TR} + \alpha^* \mathbf{Y}_{RS}), \quad \alpha = 1 e^{j2\pi/3} \quad (6)$$

and  $\|\mathbf{u}\|$  denotes a three-phase rms value of the supply voltage, which for sinusoidal voltages is equal to

$$\|\mathbf{u}\| = \sqrt{U_R^2 + U_S^2 + U_T^2}. \quad (7)$$

The line voltage rms values in the last formula should be measured with respect to an artificial zero. Unfortunately, an equivalent power equation for three-phase, four-wire systems has not yet been developed.

A power equation with an unbalanced power was also introduced in 2000 by IEEE Standard 1459 [32, 33]. This equation for sinusoidal supply voltage has the form

$$S_e^2 = P^{+2} + Q^{+2} + S_U^2 \quad (8)$$

where  $S_e = S$ , and  $P^+$  and  $Q^+$  are the active and reactive powers of the positive sequence symmetrical component of the supply voltages and currents. When the supply voltage is sinusoidal and symmetrical, then  $P^+ = P$ ,  $Q^+ = Q$ , and there is no difference between unbalanced powers in (5) and (8). Otherwise, these are two different power quantities.

Equation (8) does not provide fundamentals for design of reactive compensators, however. The unbalanced power  $S_U$  has occurred in this equation as a consequence of the observation that in unbalanced systems

$$P^{+2} + Q^{+2} \leq S_e^2 \quad (9)$$

and this has led to the definition of the unbalanced power  $S_U$  as a sort of complementary power, defined in Section 3.2.2.11 of [33] as

$$S_U = \sqrt{S_e^2 - (P^{+2} + Q^{+2})} \quad (10)$$

It is not expressed in terms of the circuit parameters, however. Consequently, parameters of a reactive compensator cannot be found having only this power value. To find them it has to be known how the unbalanced power depends on the circuit parameters. As demonstrated in [31], the unbalanced power  $D_u$ , defined by formula (5), provides fundamentals for reactive compensator design, because it is expressed in terms of the circuit parameters. It is enough to replace the load admittances in formula (6) by the compensator admittances. To apply this idea of design of reactive balancing compensators for four-wire systems, the power equation (4) and the unbalanced power definition have to be generalized for systems with a neutral conductor.

## II. POWER EQUATION

This paper is confined to studies on powers and reactive compensation of linear, time-invariant (LTI) single-phase loads supplied from three-phase sources with zero internal impedance and sinusoidal and symmetrical voltage in four-wire systems. Loads can be connected to a neutral conductor or be supplied with line-to-line voltages as shown in Fig. 2. It is assumed moreover that loads and supply lines are not mutually coupled and are of zero impedance.

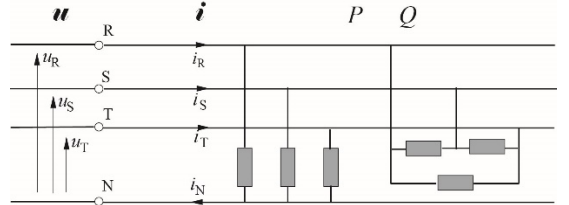

Fig. 2. Loads in four-wire system.

Symbols  $\mathbf{u}$  and  $\mathbf{i}$  in Figs. 1 and 2 denote three-phase vectors of line-to-neutral voltages and line currents, namely

$$\mathbf{u} \stackrel{\text{df}}{=} [u_R, u_S, u_T]^T, \quad \mathbf{i} \stackrel{\text{df}}{=} [i_R, i_S, i_T]^T \quad (11)$$

and although these are vectors, they will be referred shortly as a voltage and a current. They can be expressed in terms of their complex rms (crms) values, known commonly as “phasors”:

$$\mathbf{U}_X \stackrel{\text{df}}{=} U_X e^{j\alpha_X}, \quad \mathbf{I}_X \stackrel{\text{df}}{=} I_X e^{j\beta_X}, \quad X \in \{R, S, T\}$$

arranged in vectors

$$\mathbf{U} = [U_R, U_S, U_T]^T, \quad \mathbf{I} = [I_R, I_S, I_T]^T \quad (12)$$

namely,

$$\mathbf{u} = \sqrt{2} \operatorname{Re}\{U e^{j\omega t}\}, \quad \mathbf{i} = \sqrt{2} \operatorname{Re}\{I e^{j\omega t}\}. \quad (13)$$

Digital signal processing of the voltage and current samples is needed for presenting voltages and currents in such a form.

Any four-wire system as shown in Fig. 2, has an equivalent circuit, shown in Fig. 3,

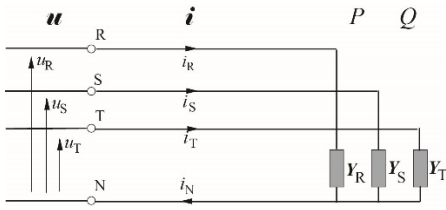

Fig. 3. Equivalent load of four-wire system.

which at the same supply voltage  $\mathbf{u}$  has the same supply currents  $\mathbf{i}$  and consequently, the same active and reactive powers  $P$  and  $Q$  at the supply terminals.

Line-to-neutral admittances of the equivalent circuit can be found by measurement of the active and reactive powers at the load terminals, as it is shown in Fig. 4. Having these values, line-to-neutral admittances are equal to

$$Y_X = G_X + jB_X = \frac{S_X^*}{U_X^2} = \frac{P_X - jQ_X}{U_X^2}, \quad X \in \{R, S, T\}. \quad (14)$$

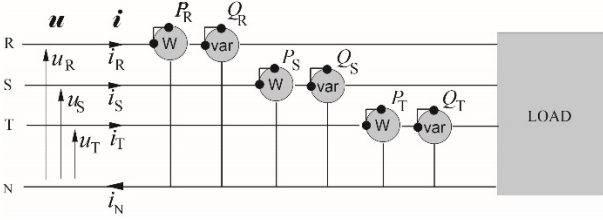

Fig. 4. Measurement of equivalent line-to-neutral admittances.

These admittances can also be calculated by measuring the crms values of the supply voltages and currents,

$$Y_X = G_X + jB_X = \frac{I_X}{U_X}. \quad (15)$$

When equivalent line-to-neutral admittances are known, then the vector of supply currents can be expressed as

$$\mathbf{i} = \sqrt{2} \operatorname{Re} \left\{ \begin{bmatrix} Y_R U_R \\ Y_S U_S \\ Y_T U_T \end{bmatrix} e^{j\omega t} \right\} = \sqrt{2} \operatorname{Re} \left\{ \begin{bmatrix} Y_R \\ Y_S \\ Y_T \end{bmatrix} \cdot \mathbf{1}^P U_R e^{j\omega t} \right\} \quad (16)$$

where

$$\mathbf{1}^P \stackrel{\text{df}}{=} [1 \quad \alpha^* \quad \alpha]^T, \quad \alpha \stackrel{\text{df}}{=} 1e^{j120^\circ}, \quad \alpha^* \stackrel{\text{df}}{=} 1e^{-j120^\circ} \quad (17)$$

denotes a unit three-phase vector of the positive sequence. Similar vectors, but of negative and zero sequence will be denoted by  $\mathbf{1}^n$  and  $\mathbf{1}^z$ , respectively

$$\mathbf{1}^n \stackrel{\text{df}}{=} [1 \quad \alpha \quad \alpha^*]^T, \quad \mathbf{1}^z \stackrel{\text{df}}{=} [1 \quad 1 \quad 1]^T. \quad (18)$$

With respect to the effectiveness of energy delivery in three-phase systems, purely resistive balanced loads are the best loads. Thus, let us extract a current of such a load from the supply current. This would be the smallest current needed to supply the load with active power  $P$ . To extract such a current let us observe that with respect to active power  $P$  the load shown in Fig. 4 is equivalent to a balanced resistive load, shown in Fig. 5,

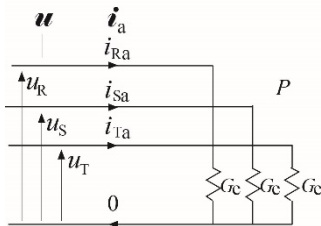

Fig. 5. Resistive balanced load equivalent to the original load respective its active power  $P$ .

on the condition that the load conductance  $G_e$  is equal to

$$G_e = \frac{P}{U_R^2 + U_S^2 + U_T^2}. \quad (19)$$

The active power of the original unbalanced load in Fig. 4, at symmetrical supply, i.e., such that

$$U_R = U_S = U_T = U, \quad \text{thus} \quad \|\mathbf{u}\| = \sqrt{3}U \quad (20)$$

is equal to

$$P = \operatorname{Re}\{Y_R^* + Y_S^* + Y_T^*\}U^2 = (G_R + G_S + G_T)U^2. \quad (21)$$

Consequently, the active power of the balanced resistive load in Fig. 4, with the load conductance

$$G_e = \frac{1}{3}(G_R + G_S + G_T) \quad (22)$$

can be calculated as

$$P = G_e \|\mathbf{u}\|^2. \quad (23)$$

Conductance  $G_e$  will be referred to as an **equivalent conductance** of a load supplied from a four-wire line. Such a resistive balanced load draws the current

$$\mathbf{i}_a(t) = G_e \mathbf{u}(t) = \sqrt{2} \operatorname{Re}\{G_e U e^{j\omega t}\} = \sqrt{2} \operatorname{Re}\{G_e \mathbf{1}^P U_R e^{j\omega t}\} \quad (24)$$

referred to as an **active current** of loads in four-wire systems. It is defined similarly as in three-wire systems [28], only the equivalent conductance  $G_e$  is defined in a different way.

The presence of the reactive power  $Q$  is not associated with the current asymmetry, but only with a phase-shift between the supply voltage and the load current. The supply source is loaded with only the reactive power and consequently, the reactive current, if a load is purely reactive and balanced. To extract the reactive current from the load current, let us observe that with respect to reactive power  $Q$ , the unbalanced load in Fig. 3 is equivalent to a balanced purely reactive load of susceptance  $B_e$  shown in Fig. 6

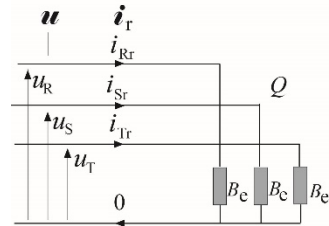

Fig. 6. Reactive balanced load equivalent to the original load respective its reactive power  $Q$ .

on the condition that the load susceptance  $B_e$  is equal to

$$B_e = -\frac{Q}{U_R^2 + U_S^2 + U_T^2}. \quad (25)$$

The negative sign in this formula is a result of a convention that inductive loads, which have negative susceptance  $B$ , have positive reactive power  $Q$ . Reactive power  $Q$  of the original load is

$$Q = \operatorname{Im}\{Y_R^* + Y_S^* + Y_T^*\}U_R^2 = -(B_R + B_S + B_T)U^2 = -B_e \|\mathbf{u}\|^2 \quad (26)$$

where

$$B_e = -\frac{Q}{\|\mathbf{u}\|^2} = \frac{1}{3}(B_R + B_S + B_T) \quad (27)$$

will be referred to as the **equivalent susceptance** of loads supplied from four-wire lines. Such a balanced reactive load draws a **reactive current**

$$\mathbf{i}_r = B_e \frac{d}{d(\omega t)} \mathbf{u} = \sqrt{2} \operatorname{Re}\{jB_e U e^{j\omega t}\} = \sqrt{2} \operatorname{Re}\{jB_e \mathbf{1}^P U_R e^{j\omega t}\}. \quad (28)$$

The active and reactive currents are currents of balanced loads and consequently, they are symmetrical of the positive sequence, while the supply current can be asymmetrical. Asymmetry of the supply current occurs due to the load imbalance. The asymmetrical component of the load current is equal to

$$\mathbf{i}_u = \mathbf{i} - \mathbf{i}_a - \mathbf{i}_r \quad (29)$$

and it can be expressed in terms of the load equivalent parameters as follows

$$\mathbf{i}_u = \sqrt{2} \text{Re} \left\{ \begin{bmatrix} \mathbf{I}_{Ru} \\ \mathbf{I}_{Su} \\ \mathbf{I}_{Tu} \end{bmatrix} e^{j\omega t} \right\} = \sqrt{2} \text{Re} \left\{ \begin{bmatrix} (Y_R - G_e - jB_e) \\ (Y_S - G_e - jB_e)\alpha^* \\ (Y_T - G_e - jB_e)\alpha \end{bmatrix} \mathbf{U}_R e^{j\omega t} \right\}. \quad (30)$$

As shown in Appendix A, the current  $\mathbf{i}_u$ , is in general an asymmetrical current, composed of symmetrical components of the negative and zero sequence,

$$\mathbf{i}_u = \mathbf{i}_u^n + \mathbf{i}_u^z \quad (31)$$

such that

$$\mathbf{i}_u^n = \sqrt{2} \text{Re} \{ A^n \mathbf{I}^n U_R e^{j\omega t} \} \quad (32)$$

with

$$A^n = \frac{1}{3} (Y_R + \alpha Y_S + \alpha^* Y_T) \quad (33)$$

and

$$\mathbf{i}_u^z = \sqrt{2} \text{Re} \{ A^z \mathbf{I}^z U_R e^{j\omega t} \} \quad (34)$$

with

$$A^z = \frac{1}{3} (Y_R + \alpha^* Y_S + \alpha Y_T). \quad (35)$$

In such a way the current of an unbalanced load supplied from a four-wire line was decomposed into four components, namely

$$\mathbf{i} = \mathbf{i}_a + \mathbf{i}_r + \mathbf{i}_u^n + \mathbf{i}_u^z. \quad (36)$$

According to eqn. (36) the supply current can be decomposed into components associated distinctively with specific phenomena in the circuit, namely,

- (i) The active current  $\mathbf{i}_a$ , associated with permanent flow of energy at the rate of active power  $P$ .
- (ii) The reactive current  $\mathbf{i}_r$ , associated with the phase-shift between the voltage and current and consequently, the presence of the reactive power  $Q$ .
- (iii) The unbalanced current of the negative sequence  $\mathbf{i}_u^n$ , associated with the load line-to-line imbalance.
- (iv) The unbalanced current of the zero sequence  $\mathbf{i}_u^z$ , associated with the load line-to-neutral imbalance.

Therefore, these four currents can be regarded as the Currents' Physical Components (CPC) of the load current.

The authors of the paper would like to strongly emphasize, however, that the adjective "physical" should not be interpreted as a suggestion that these currents exist physically. They are only mathematical entities, as observed in [37]. They are *associated* with distinctive physical phenomena in the circuit, however.

The three-phase rms values of these currents are equal to

$$\|\mathbf{i}_a\| = G_e \|\mathbf{u}\| \quad (37)$$

$$\|\mathbf{i}_r\| = |B_e| \|\mathbf{u}\| \quad (38)$$

$$\|\mathbf{i}_u^n\| = A^n \|\mathbf{u}\| \quad (39)$$

$$\|\mathbf{i}_u^z\| = A^z \|\mathbf{u}\|. \quad (40)$$

Scalar products, defined for three-phase vectors  $\mathbf{x}(t)$  and  $\mathbf{y}(t)$  as

$$(\mathbf{x}, \mathbf{y}) \stackrel{\text{df}}{=} \frac{1}{T} \int_0^T \mathbf{x}^T(t) \mathbf{y}(t) dt \quad (41)$$

of these four components, as shown in Appendix B, are equal to zero, which means that they are mutually orthogonal. Consequently, their three-phase rms values satisfy the relationship

$$\|\mathbf{i}\|^2 = \|\mathbf{i}_a\|^2 + \|\mathbf{i}_r\|^2 + \|\mathbf{i}_u^n\|^2 + \|\mathbf{i}_u^z\|^2. \quad (42)$$

The relationship between three-phase value of these currents can be illustrated with a diagram shown in Fig. 7.

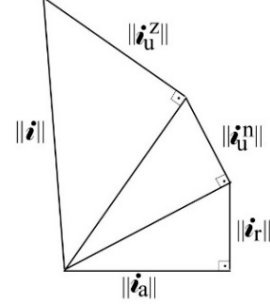

Fig. 7. Diagram of three-phase rms values of CPC.

Observe however, that orthogonality of four currents cannot be illustrated on a plane. This would be possible only in a four-dimensional space. Only two sides can be drawn on a plane as orthogonal. The sequence on the right side of eqn. (42) can be changed, however, and consequently, the shape of the diagram, with the same length of diagonal  $\|\mathbf{i}\|$ . The number of such diagrams is equal to the factorial of four,  $4! = 24$ . To illustrate orthogonality of two selected quantities, they should be placed as the first terms of equation (36).

Multiplying formula (42) by the square of load voltage three-phase rms value  $\|\mathbf{u}\|$ , the power equation is obtained

$$S^2 = P^2 + Q^2 + D_u^n^2 + D_u^z^2 \quad (43)$$

with

$$P = \|\mathbf{u}\| \|\mathbf{i}_a\| = G_e \|\mathbf{u}\|^2 \quad (44)$$

$$Q = \pm \|\mathbf{u}\| \|\mathbf{i}_r\| = -B_e \|\mathbf{u}\|^2 \quad (45)$$

$$D_u^n = \|\mathbf{u}\| \|\mathbf{i}_u^n\| = A^n \|\mathbf{u}\|^2 \quad (46)$$

$$D_u^z = \|\mathbf{u}\| \|\mathbf{i}_u^z\| = A^z \|\mathbf{u}\|^2. \quad (47)$$

The power equation (43) is secondary to the current decomposition (36) into physical components, however. While current physical components are associated with distinctive physical phenomena, apart from the active power,  $P$ , other powers are only some measures that indicate how distinctive phenomena contribute to the apparent power  $S$  increase above  $P$  value. All of them have an important feature: they are specified not only in terms of the voltage and currents rms values, but also in terms of equivalent parameters  $G_e$ ,  $B_e$ ,  $A^n$  and  $A^z$  of the load.

Power equation (43) contains two new power quantities,  $D_u^n$  and  $D_u^z$ . They are associated with the presence of the negative and the zero sequence unbalanced components in the supply current. Therefore, they will be called *negative sequence unbalanced power* and *zero sequence unbalanced power*, respectively. The power equation can be illustrated geometrically with a diagram shown in Fig. 8.

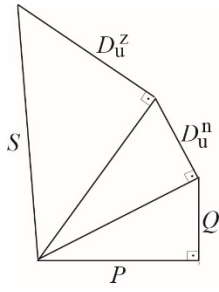

Fig. 8. Diagram of powers of LTI load.

The sequence of powers in power equation (43) could be different and consequently, the shape of the diagram. Similarly as it was with currents, there are  $4! = 24$  different diagrams of the load powers.

Observe, that the crms value of the negative sequence component  $\mathbf{i}_u^n$  of the supply current in line S, according to formula (32) is

$$\mathbf{I}_{Su}^n = \mathbf{A}^n \alpha \mathbf{U}_R = \mathbf{A}^n \alpha^* \mathbf{U}_S = (\alpha^* \mathbf{A}^n) \mathbf{U}_S \quad (48)$$

and in line T

$$\mathbf{I}_{Tu}^n = \mathbf{A}^n \alpha^* \mathbf{U}_S = \mathbf{A}^n \alpha \mathbf{U}_T = (\alpha \mathbf{A}^n) \mathbf{U}_T. \quad (49)$$

Similarly, the crms value of the zero sequence component  $\mathbf{i}_u^z$  of the current in line S, according to formula (34) is

$$\mathbf{I}_{Su}^z = \mathbf{A}^z \mathbf{U}_R = \mathbf{A}^z \alpha \mathbf{U}_S = (\alpha \mathbf{A}^z) \mathbf{U}_S \quad (50)$$

and in line T

$$\mathbf{I}_{Tu}^z = \mathbf{A}^z \mathbf{U}_R = \mathbf{A}^z \alpha^* \mathbf{U}_T = (\alpha^* \mathbf{A}^z) \mathbf{U}_T. \quad (51)$$

Therefore, formulae (24), (28), (32) and (34) specify current in a circuit, which can be drawn as shown in Fig. 9. It will be referred to as an **equivalent circuit** of LTI loads supplied from a three-wire line with a neutral conductor.

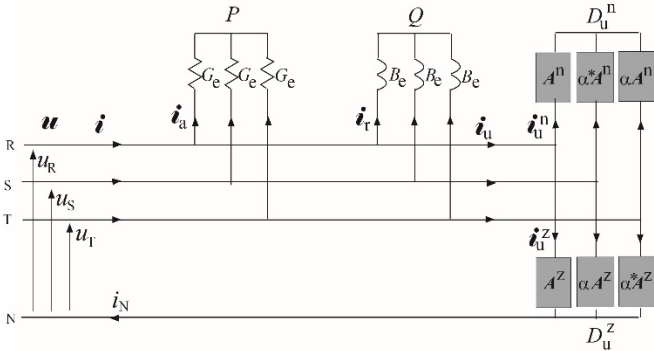

Fig. 9. Equivalent circuit of LTI load supplied from four-wire line with symmetrical sinusoidal voltage.

Observe that the total unbalanced power  $D_u$  of the load can be calculated from direct measurement of the active and reactive powers  $P$  and  $Q$  in the circuit shown in Fig. 4, and by calculating the apparent power  $S$ , as defined by Buchholz with formula (3), from rms values of the line currents and voltages measurements. Having these three powers, the total unbalanced power can be calculated, namely

$$D_u = \sqrt{S^2 - (P^2 + Q^2)}. \quad (52)$$

It cannot be decomposed, however, into the negative and the zero sequence unbalanced powers  $D_u^n$  and  $D_u^z$  without the knowledge of the rms value of the negative and zero sequence components of the load currents. The knowledge of all these powers is not sufficient for designing a balancing compensator, according to the method explained in Section IV, however. As it will be shown, unbalanced admittances  $\mathbf{A}^n$ ,  $\mathbf{A}^z$  and equivalent susceptance  $B_e$  of the load have to be known for that.

**Illustration 1.** Let us calculate the active, reactive and both unbalanced powers for the unbalanced load shown in Fig. 10, assuming that  $U_R = 120$  V.

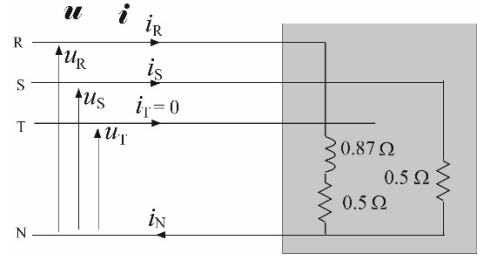

Fig. 10. Example of unbalanced load.

For such a load, the equivalent admittance is equal to

$$\mathbf{Y}_e = G_e + jB_e = \frac{1}{3}(0.50 - j0.87 + 2.0) = 0.83 - j0.29 \text{ S.}$$

The negative sequence unbalanced admittance is

$$\begin{aligned} \mathbf{A}^n &= \frac{1}{3}(\mathbf{Y}_R + \alpha \mathbf{Y}_S + \alpha^2 \mathbf{Y}_T) = \frac{1}{3}(0.5 - j0.87 + 1e^{-j120^\circ} \times 0.5) = \\ &= 0.33e^{-120.1^\circ} \text{ S} \end{aligned}$$

while the zero sequence unbalanced admittance has the value

$$\begin{aligned} \mathbf{A}^z &= \frac{1}{3}(\mathbf{Y}_R + \alpha^2 \mathbf{Y}_S + \alpha \mathbf{Y}_T) = \frac{1}{3}(0.5 - j0.87 + 1e^{j120^\circ} \times 0.5) = \\ &= 0.88e^{-j101^\circ} \text{ S.} \end{aligned}$$

Since

$$\|\mathbf{u}\| = \sqrt{3} U_R = \sqrt{3} \times 120 = 207.8 \text{ V}$$

the particular powers are equal to

$$P = G_e \|\mathbf{u}\|^2 = 0.83 \times (207.8)^2 = 36.0 \text{ kW}$$

$$Q = -B_e \|\mathbf{u}\|^2 = 0.29 \times (207.8)^2 = 12.5 \text{ kvar}$$

$$D_u^n = \mathbf{A}^n \|\mathbf{u}\|^2 = 0.33 \times (207.8)^2 = 7.2 \text{ kVA}$$

$$D_u^z = \mathbf{A}^z \|\mathbf{u}\|^2 = 0.88 \times (207.8)^2 = 38.0 \text{ kVA.}$$

### III. POWER FACTOR

The power factor of LTI loads supplied with symmetrical sinusoidal voltage in three-phase systems with neutral conductor is equal to

$$\lambda = \frac{P}{S} = \frac{P}{\sqrt{P^2 + Q^2 + D_u^{n2} + D_u^{z2}}} \quad (53)$$

thus, not only the reactive power  $Q$ , but also both unbalanced powers,  $D_u^n$  and  $D_u^z$  contribute to the load power factor degradation. The power factor can be expressed not only in terms of powers, but also in terms of three-phase rms values of CPCs of the supply current, namely

$$\lambda = \frac{P}{S} = \frac{\|\mathbf{i}_a\|}{\|\mathbf{i}\|} = \frac{\|\mathbf{i}_a\|}{\sqrt{\|\mathbf{i}_a\|^2 + \|\mathbf{i}_t\|^2 + \|\mathbf{i}_u^n\|^2 + \|\mathbf{i}_u^z\|^2}}. \quad (54)$$

Particularly important is the possibility of expressing the power factor in terms of the load parameters, in particular, in terms of the equivalent conductance,  $G_e$ , susceptance,  $B_e$  and the magnitude of unbalanced admittances  $\mathbf{A}^n$  and  $\mathbf{A}^z$

$$\lambda = \frac{\|\mathbf{i}_a\|}{\|\mathbf{i}\|} = \frac{G_e}{\sqrt{G_e^2 + B_e^2 + \mathbf{A}^{n2} + \mathbf{A}^{z2}}}. \quad (55)$$



Thus, the power factor of loads supplied from a four-wire line declines from unity value because of non-zero equivalent susceptance  $B_e$  of the load, the negative sequence unbalanced admittance  $A^n$  and the zero sequence unbalanced admittance  $A^z$ . This last formula emphasizes the fact that the power factor depends only on the load properties, but not on voltages, currents or powers. It is defined in terms of the active and apparent powers, but eventually, only the load properties specify the power factor value. Also, in a case of reactive compensation, only a change by means of such a compensator of the parameters as seen by the supply makes the power factor improvement possible.

The power equation developed in this Section is valid at symmetrical sinusoidal voltage, which supplies an unbalanced, but linear, time-invariant load. Development of this equation will not terminate studies on this subject. New ideas will occur, as for example, discussed in paper [34]. Nonetheless, as presented in this paper the CPC approach seems to be very fruitful and opens a gate to studies on powers in three-phase systems in situations more complex than that considered in this paper.

#### IV. REACTIVE COMPENSATION

A reactive compensator can be built, in general, of three inductors and/or capacitors connected between supply lines and the neutral conductor, meaning in Y structure or connected between supply lines, meaning in  $\Delta$  structure. Since compensators in  $\Delta$  structure cannot affect the neutral current, let us focus our attention on reactive compensators in Y structure, as shown in Fig. 11.

The compensator in Fig. 11 is composed of three reactive devices of susceptance  $T_R$ ,  $T_S$  and  $T_T$ . It is assumed here that these devices are lossless, meaning their conductance  $G$  is equal to zero.

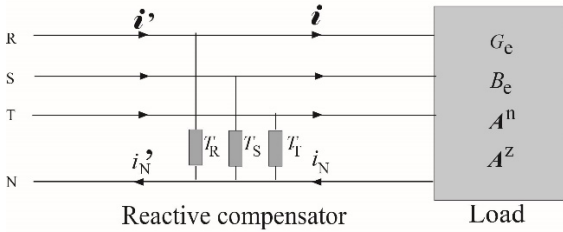

Fig. 11. LTI load with reactive compensator in Y structure.

The negative sequence component  $\mathbf{i}_u^n$  of the unbalanced current is compensated entirely on the condition that

$$\frac{1}{3}j(T_R + \alpha T_S + \alpha^* T_T) + A^n = 0 \quad (56)$$

while the zero sequence component  $\mathbf{i}_u^z$  of this current is entirely compensated on the condition that

$$\frac{1}{3}j(T_R + \alpha^* T_S + \alpha T_T) + A^z = 0. \quad (57)$$

If along with the unbalanced current such a compensator should also compensate the reactive current, then its parameters should moreover satisfy condition

$$\frac{1}{3}(T_R + T_S + T_T) + B_e = 0. \quad (58)$$

Equations (56) and (57) have to be satisfied for the real part and for imaginary part of these equations separately, thus each of them represents two equations. Thus, three susceptances  $T_R$ ,  $T_S$  and  $T_T$  of the compensator have to satisfy five equations, meaning the set of these equations is contradictory. A compensator of structure as shown in Fig. 11 cannot compensate simultaneously the reactive and unbalanced currents. Even the unbalanced current alone cannot be compensated, because equations (56) and (57) with only three unknown parameters are contradictory. A second compensator is needed for compensation of the unbalanced and reactive currents.

In general, the compensator could have the structure as shown in Fig. 12, composed of a compensator in Y configuration and a compensator in  $\Delta$  configuration.

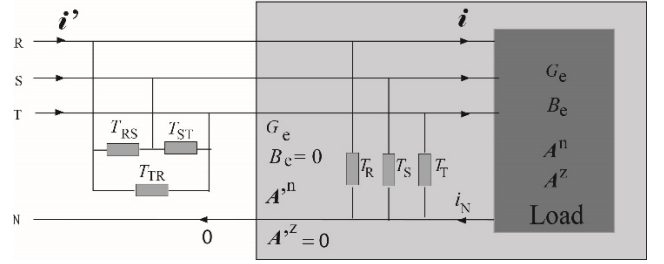

Fig. 12. General structure of the reactive balancing compensator

The sequence of  $\Delta$  and Y compensators can be switched, which changes the compensator structure. Moreover, the reactive current can be compensated entirely by  $\Delta$ , by Y compensator or even by both of them. Thus, the load can be compensated by reactive compensators of different structure and parameters.

Since procedures of calculation of their parameters do not differ substantially, only one of them will be considered in this paper.

Let us assume that in the first step of compensation the reactive current  $\mathbf{i}_r$  and the unbalanced current of the zero sequence  $\mathbf{i}_u^z$  are compensated by a compensator of Y structure, connected as shown in Fig. 12. Its susceptances have to satisfy equation (57) and (58). The solution of these equations results in the compensator parameters

$$\begin{aligned} T_R &= -2\text{Im}A^z - B_e \\ T_S &= -\sqrt{3}\text{Re}A^z + \text{Im}A^z - B_e \\ T_T &= \sqrt{3}\text{Re}A^z + \text{Im}A^z - B_e. \end{aligned} \quad (59)$$

The zero sequence unbalanced admittance of such a compensator is equal to  $A_C^z = -A^z$ . Let us calculate the negative sequence admittance of this compensator, i.e.,

$$\begin{aligned} A_C^n &= \frac{1}{3}j(T_R + \alpha T_S + \alpha^* T_T) = \frac{1}{3}j[(-2\text{Im}A^z - B_e) + \\ &+ \alpha(-\sqrt{3}\text{Re}A^z + \text{Im}A^z - B_e) + \alpha^*(\sqrt{3}\text{Re}A^z + \text{Im}A^z - B_e)] = \\ &= \text{Re}A^z - j\text{Im}A^z = A^{z*}. \end{aligned} \quad (60)$$

Thus, such a compensator reduces the zero sequence component  $\mathbf{i}_u^z$  of the unbalanced current to zero, but changes the negative sequence component  $\mathbf{i}_u^n$  to

$$\mathbf{i}_u^n = \sqrt{2}\text{Re}\{(A_C^n + A^n)\mathbf{1}^n U_R e^{j\omega t}\} = \sqrt{2}\text{Re}\{A'^n \mathbf{1}^n U_R e^{j\omega t}\}. \quad (61)$$

It means, that the load with the compensator of Y structure has unbalanced admittance of the negative sequence equal to

$$A'^n = A_C^n + A^n = A^{z*} + A^n. \quad (62)$$

According to [30], the unbalanced admittance of a load configured in  $\Delta$  is equal to

$$A^n = -(\mathbf{Y}_{ST} + \alpha \mathbf{Y}_{TR} + \alpha^* \mathbf{Y}_{RS}). \quad (63)$$

Applying this formula to a reactive compensator and assuming that one of admittances, for example  $\mathbf{Y}_{RS}$ , is equal to zero, susceptances  $T_{ST}$  and  $T_{TR}$  should satisfy equation

$$-(jT_{ST} + \alpha jT_{TR} + \alpha^* jT_{RS}) + A'^n = 0 \quad (64)$$

along with the condition that the compensator equivalent susceptance

$$B_e C = T_R + T_S + T_T = 0 \quad (65)$$

because the reactive power of the load is compensated by the Y structure compensator. Equations (64) and (65) have solution

$$\begin{aligned} T_{RS} &= (\sqrt{3}\text{Re}A'^n - \text{Im}A'^n)/3 \\ T_{ST} &= (2\text{Im}A'^n)/3 \\ T_{TR} &= (-\sqrt{3}\text{Re}A'^n - \text{Im}A'^n)/3. \end{aligned} \quad (66)$$

In effect of such compensation, the load supplied from a three-wire line with neutral conductor is balanced with the reactive power equal to zero, thus it operates at unity power factor  $\lambda$ . The compensated load is equivalent to a purely resistive balanced three-phase load of conductance, per phase, equal to the equivalent conductance  $G_e$ .

**Illustration 2.** Let us calculate parameters of a reactive compensator for a load shown in Fig. 13 and supply currents, assuming that the supply voltage rms value is equal to  $U = 120$  V and  $\omega = 1$  rad/s.

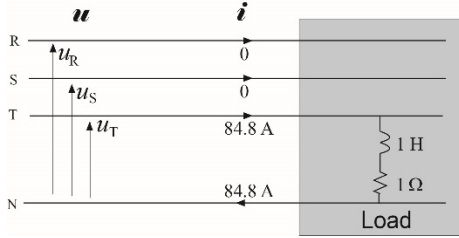

Fig. 13. Unbalanced load.

The equivalent admittance of the load is equal to

$$\begin{aligned} Y_e &= G_e + jB_e = \frac{1}{3}(Y_R + Y_S + Y_T) = \frac{1}{3} \frac{1}{1+j1} = \\ &= 0.167 - j0.167 \text{ S} \end{aligned}$$

while the unbalanced admittances are

$$\begin{aligned} A^n &= \frac{1}{3}(Y_R + \alpha Y_S + \alpha^2 Y_T) = \frac{1}{3} \alpha^2 Y_T = \frac{1}{3} \alpha^2 \frac{1}{1+j1} = \\ &= 0.236 e^{-j165^\circ} = -0.228 - j0.061 \text{ S} \\ A^z &= \frac{1}{3}(Y_R + \alpha^* Y_S + \alpha Y_T) = \frac{1}{3} \alpha Y_T = \frac{1}{3} \alpha \frac{1}{1+j1} = \\ &= 0.236 e^{j75^\circ} = 0.061 + j0.228 \text{ S}. \end{aligned}$$

Since the three-phase rms value of the supply voltage is

$$\|\mathbf{u}\| = \sqrt{3}U_R = \sqrt{3} \times 120 = 207.8 \text{ V}$$

the rms values of the Currents' Physical Components of the considered load are equal to

$$\begin{aligned} \|\mathbf{i}_a\| &= G_e \|\mathbf{u}\| = 0.167 \times 207.8 = 34.7 \text{ A} \\ \|\mathbf{i}_r\| &= |B_e| \|\mathbf{u}\| = 0.167 \times 207.8 = 34.7 \text{ A} \\ \|\mathbf{i}_u^n\| &= A^n \|\mathbf{u}\| = 0.236 \times 207.8 = 49.0 \text{ A} \\ \|\mathbf{i}_u^z\| &= A^z \|\mathbf{u}\| = 0.236 \times 207.8 = 49.0 \text{ A}. \end{aligned}$$

The rms value of the load current is

$$\|\mathbf{i}\| = \sqrt{\|\mathbf{i}_a\|^2 + \|\mathbf{i}_r\|^2 + \|\mathbf{i}_u^n\|^2 + \|\mathbf{i}_u^z\|^2} = 84.9 \text{ A}$$

and the power factor

$$\lambda = \frac{P}{S} = \frac{\|\mathbf{i}_a\|}{\|\mathbf{i}\|} = 0.41.$$

Susceptances of the compensator of the zero sequence unbalanced and reactive currents, configured in Y, and connected as shown in Fig. 14

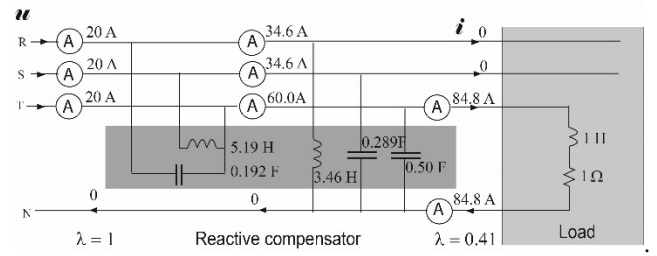

Fig. 14. Example of load with reactive compensator

have values

$$\begin{aligned} T_R &= -2\text{Im}A^z - B_e = -0.289 \text{ S} \\ T_S &= -\sqrt{3}\text{Re}A^z + \text{Im}A^z - B_e = 0.289 \text{ S} \\ T_T &= \sqrt{3}\text{Re}A^z + \text{Im}A^z - B_e = 0.50 \text{ S}. \end{aligned}$$

The crms values of the line currents after compensation with the Y compensator are equal to

$$I_R = 34.64 e^{-j90^\circ} \text{ A}, \quad I_S = 34.64 e^{-j30^\circ} \text{ A}, \quad I_T = 60.0 e^{j120^\circ} \text{ A}.$$

The compensator changes the unbalanced admittance of the load and the Y-configured compensator to

$$\begin{aligned} A'^n &= A^{z*} + A^n = (0.061 + j0.228)^* - 0.228 - j0.061 = \\ &= -0.167 - j0.289 \text{ S} \end{aligned}$$

thus, susceptances of the  $\Delta$  compensator are equal to

$$\begin{aligned} T_{RS} &= (\sqrt{3}\text{Re}A'^n - \text{Im}A'^n)/3 = 0 \\ T_{ST} &= (2\text{Im}A'^n)/3 = -0.192 \text{ S} \\ T_{TR} &= (-\sqrt{3}\text{Re}A'^n - \text{Im}A'^n)/3 = 0.192 \text{ S}. \end{aligned}$$

The  $\Delta$  compensator should be composed of an inductor of inductance

$$L_{ST} = -\frac{1}{\omega_1 T_{ST}} = 5.19 \text{ H}$$

and a capacitor of capacitance

$$C_{TR} = \frac{T_{TR}}{\omega_1} = 0.192 \text{ F}.$$

The results of compensation are shown in Fig. 14. The compensator eliminates both the reactive and unbalanced components from the supply current, meaning it improves the power factor to unity.

## V. CONCLUSIONS

Reactive compensation in three-phase systems with a neutral conductor is more complex than such compensation in three-wire systems. The number of the compensator's reactive components required for total compensation can even double. Nonetheless, reactive current can always be totally compensated, and the load can be fully balanced for any linear, time-invariant unbalanced load supplied with a symmetrical and sinusoidal voltage.

The paper presents fundamentals of reactive compensation of linear loads with fixed parameters. Usually these parameters change in time, however. An adaptive compensator might be needed for such a situation. Fundamentals of design of an adaptive compensator of reactive power with thyristor switched inductors (TSI) were presented in [35]. Design and control of an adaptive balancing compensator for three-wire systems were presented in [36]. The last paper discusses adaptive reactive compensation in three-wire systems, but the same approach and technology can be applied to adaptive compensation in four-wire systems. Discussion of such an adaptive compensation is beyond of the scope of this paper, however. The same applies to

compensation in the presence of supply voltage harmonics and/or the supply voltage asymmetry. Nonetheless, this paper could be regarded as a starting point for studies on compensation in more complex situations.

## REFERENCES

- [1] F. de Leon, J. Cohen, "AC power theory from Poynting Theorem: accurate identification of instantaneous power components in nonlinear-switched circuits", *IEEE Trans. on Power Del.*, 2010, Vol. 25, No. 4, pp. 2104-2112.
- [2] W.G. Morsi, M.E. El-Hawary, "Defining power components in nonsinusoidal unbalanced polyphase systems: the issues", *IEEE Trans. on Power Del.*, 2007, Vol. 22, No. 4, pp. 2428-2437.
- [3] F. de Leon, J. Cohen, "A practical approach to power factor definitions: transmission losses, reactive power compensation, and machine utilization", *Proc. of the Power Eng. Soc. 2006 Meeting*, IEEE Dig. Obj. Ident.: 10.1109/PES.2006.1709175.
- [4] F. Ghassemi, "New concept in AC power theory", *IET Gen. Transm., Distr.*, 2000, Vol. 147, No. 6, pp. 414-424.
- [5] F. Ghassemi, "What is wrong with power theory and how it should be modified", *Proc. of Metering and Tariffs for Energy Supply Conf.*, Publ. No. 462©IEE 1999, pp. 109-114.
- [6] Z. Hanzelka, Y. Varetzky, "Negative-sequence active power stream as an index of unbalanced source", *Proc. of Electric Power Quality and Utilization (EPQU) Conf.*, Dig. Obj. Ident.: 10.1109/EPQU.2011.6128928.
- [7] M.A.S. Masoum, P.S. Moses, A.S. Masoum, "Derating of asymmetrical three-phase transformers serving unbalanced nonlinear loads", *IEEE Trans. on Power Del.*, 2008, Vol. 23, No. 4, pp. 2033-2041.
- [8] H. Akagi, Y. Kanazawa, A. Nabae, "Instantaneous reactive power compensator comprising switching devices without energy storage components", *IEEE Trans. IA*, 1984, IA-20, No. 3, pp. 625-630
- [9] H.L. Ginn, G. Chen, "Switching compensator control strategy based on CPC power theory", *Przegląd Elektrotechniczny*, 2008, Vol. 84, No. 6, pp. 23-27.
- [10] H. Akagi at all., "Compensation algorithms based on the p-q and CPC theories for switching compensators in micro-grids", *Proc. of COBEP 09 Power Electronics Conference*, 2009, Brazilian DOI: 10.1109/ COBEP.2009.5347593, pp. 32-40.
- [11] P. Tenti at all., "Compensation of unbalance, reactive power and harmonic distortion by cooperative operation of distributed compensators", *Proc. of the European Conf. on Power Electronics Appl.*, 2009, pp. 1-10.
- [12] M. Popescu, A. Bitoleanu, V. Suru, "Currents' Physical Components theory implementation in shunt active power filtering for unbalanced loads", *Proc. of the Int. School on Nonsinusoidal Currents and Compensation, ISNCC, 2013*, Dig. Obj. Ident.: 10.1109/ISNCC.2013.6604447.
- [13] Ch.P Steinmetz, *Theory and calculation of electrical apparatus*, McGraw-Hill Book Comp., New York, 1917.
- [14] W.V. Lyon, "Reactive power and unbalanced circuits", *Electrical World*, June 1920, pp. 1417-1420.
- [15] AIEE Committee, "Apparent power in three-phase systems", *Trans. of AIEE*, 1920, Vol. 39, pp. 1450-1455.
- [16] F. Buchholz, "Die Drehstrom-Scheinleistung bei ungleichmäßiger Belastung der drei Zweige", *Licht und Kraft*, January 1922, pp. 9-11.
- [17] H.L. Curtis, F.B. Silsbee, "Definitions of power and related quantities", *Transactions of AIEE*, 1935, Vol. 54, pp. 394-404.
- [18] L.S. Czarnecki, "Energy flow and power phenomena in electrical circuits: illusions and reality", *Archiv für Elektrot.*, 1999, (82), No. 4, pp. 10-15.
- [19] M. Grandpierr, B. Trannoy, "A stationary power device to rebalance and compensate reactive power in three-phase network", *Proc of 1977 IAS Annual Conference*, pp. 127-135.
- [20] G. Klinger, "LC Compensation und symmetrisierung für Mehrphasensysteme mit beliebigen Spannungsverlauf", *ETZ Archiv*, 1979, H.2, pp. 57-61.
- [21] J.E. Miller, *Reactive power control in electric systems*, John Willey & Sons, 1982.
- [22] L.S. Czarnecki, "Minimization of unbalanced currents in three-phase asymmetrical circuits with nonsinusoidal voltage", *IEE Proc.-B*, 1992, Vol. 139, No. 4, pp. 347-354.
- [23] S.Y. Lee, C.J. Wu, "On-line reactive power compensation schemes for unbalanced three-phase four wire distribution systems", *IEEE Trans. on Power Del.*, 1993, Vol. 8, no. 4, pp. 1235-1239.
- [24] L.S. Czarnecki, "Supply and loading quality improvement in sinusoidal power systems with unbalanced loads supplied with asymmetrical voltage", *Archiv für Elektrotechnik*, 1994, Vol. 77, pp. 169-177.
- [25] L.C. Oriega De Oliviera, M.C. Barros Neto, J.B. de Souza, "Load compensation in four-wire electrical power systems", *Proc. of Int. Conf. on Power System Technology*, 2000, Vol. 3, pp. 1975-1580.
- [26] L. Sainz, M. Caro, E. Caro, "Analytical study of series resonance in power systems with the Steinmetz circuit", *IEEE Trans. on Power Del.*, 2009, Vol. 24, no. 4, pp. 2090-2099.
- [27] D. Mayer, P. Kropik, "New approach to symmetrization of three-phase networks", *Int. Journ. of Electrical Engineering*, 2005, Vol. 56, No. 5-6, pp. 156-161.
- [28] C. Arendse, G. Atkinson-Hope, "Design of Steinmetz symmetrizer and application in unbalanced network", *Proc. of UPEC 2010 Conference*.
- [29] S-J. Jeon, J.L. Willens, "Reactive power compensation in multi-line systems under sinusoidal unbalanced conditions," *Int. J. on Circuit Theory and Applications*, 2011, 39, pp. 211-224.
- [30] L.S. Czarnecki, "Orthogonal decomposition of the current in a three-phase non-linear asymmetrical circuit with nonsinusoidal voltage", *IEEE Trans. IM.*, 1988, Vol. IM-37, No. 1, pp. 30-34.
- [31] L.S. Czarnecki, "Reactive and unbalanced currents compensation in three-phase circuits under nonsinusoidal conditions", *IEEE Trans. IM*, June 1989, IM-38, No. 3, pp. 754-459.
- [32] *IEEE Trial use standard for the measurement of electric power quantities under sinusoidal, nonsinusoidal, balanced and unbalanced conditions*. IEEE 1459-2000.
- [33] *IEEE standard definitions for the measurement of electric power quantities under sinusoidal, nonsinusoidal, balanced and unbalanced conditions*. IEEE 1459-2010.
- [34] M. Castro-Nunez, R. Castro-Puche, "The IEEE Standard 1459, the CPC power theory and geometric algebra in circuits with nonsinusoidal sources and linear loads", *IEEE Trans. on Circuits and Systems - I*, 2012, Vol. 59, No. 12, pp. 2980-2990.
- [35] L. Gyugyi, R.A. Otto, T.H. Putman, "Principles and applications of stationary thyristor-controlled shunt compensators", *IEEE Trans. on Power App. and Systems*, 1976, pp. 1935-1945.
- [36] L.S. Czarnecki, S.M. Hsu, G. Chen, "Adaptive balancing compensator", *IEEE Trans. Pow. Delivery*, 1996, Vol. 10, No. 3, 1663-1669.
- [37] F. de Leon, J. Cohen, "Discussion of "Instantaneous Reactive Power p-q Theory and power properties of three-phase systems", *IEEE Trans. on Power Del.*, 2008, Vol. 23, No. 3, pp. 1693-1694.

## Appendix A

### Symmetrical components of unbalanced current

The unbalanced current  $\mathbf{i}_u$  as defined by formula (30) can be decomposed into symmetrical components of the positive, negative and the zero sequence.

The crms value of the positive sequence of this current is equal to

$$\begin{aligned} I_u^p &= \frac{1}{3}(I_{Ru} + \alpha I_{Su} + \alpha^* I_{Tu}) = \\ &= \frac{1}{3}[(Y_R - G_e - jB_e) + \alpha(Y_S - G_e - jB_e)\alpha^* + \alpha^*(Y_T - G_e - jB_e)\alpha]U_R = \\ &= \frac{1}{3}[(Y_R + Y_S + Y_T) - 3G_e - j3B_e]U_R = 0. \end{aligned} \quad (A1)$$

Thus, the unbalanced current does not contain any component of the positive sequence.

The crms value of the negative sequence component of the unbalanced current is equal to

$$\begin{aligned} I_u^n &= \frac{1}{3}(I_{Ru} + \alpha^* I_{Su} + \alpha I_{Tu}) = \\ &= \frac{1}{3}[(Y_R - G_e - jB_e) + \alpha^*(Y_S - G_e - jB_e)\alpha + \alpha(Y_T - G_e - jB_e)]U_R = \\ &= \frac{1}{3}(Y_R + \alpha Y_S + \alpha^* Y_T)U_R = A^n U_R \end{aligned} \quad (A2)$$

where

$$A^n = \frac{1}{3}(Y_R + \alpha Y_S + \alpha^* Y_T). \quad (A3)$$

The crms value of the zero sequence component of the unbalanced current is equal to

$$\begin{aligned} I_u^z &= \frac{1}{3}(I_{Ru} + I_{Su} + I_{Tu}) = \\ &= \frac{1}{3}[(Y_R - G_e - jB_e) + (Y_S - G_e - jB_e)\alpha^* + (Y_T - G_e - jB_e)\alpha]U_R = \\ &= \frac{1}{3}(Y_R + \alpha^* Y_S + \alpha Y_T)U_R = A^z U_R \end{aligned} \quad (A4)$$



where

$$\mathbf{A}^z \stackrel{\text{df}}{=} \frac{1}{3}(\mathbf{Y}_R + \alpha^* \mathbf{Y}_S + \alpha \mathbf{Y}_T). \quad (\text{A5})$$

## Appendix B

### Orthogonality of Current's Physical Components

The three-phase rms value of vector  $\mathbf{x}(t)$  is defined as

$$\|\mathbf{x}\| \stackrel{\text{df}}{=} \sqrt{\frac{1}{T} \int_0^T \mathbf{x}^T(t) \mathbf{x}(t) dt} \quad (\text{B1})$$

hence, the three-phase rms value of a sum of three-phase vectors  $\mathbf{x}(t)$  and  $\mathbf{y}(t)$  is equal to

$$\begin{aligned} \|\mathbf{x} + \mathbf{y}\| &= \sqrt{\frac{1}{T} \int_0^T [\mathbf{x}(t) + \mathbf{y}(t)]^T [\mathbf{x}(t) + \mathbf{y}(t)] dt} \\ &= \sqrt{\|\mathbf{x}\|^2 + 2(\mathbf{x}, \mathbf{y}) + \|\mathbf{y}\|^2} \end{aligned} \quad (\text{B2})$$

where

$$(\mathbf{x}, \mathbf{y}) \stackrel{\text{df}}{=} \frac{1}{T} \int_0^T \mathbf{x}^T(t) \mathbf{y}(t) dt \quad (\text{B3})$$

denotes the scalar product of three-phase quantities  $\mathbf{x}(t)$  and  $\mathbf{y}(t)$ .

According to formula (B2) the three-phase rms value of a sum of three-phase vectors  $\mathbf{x}(t)$  and  $\mathbf{y}(t)$  can be calculated as a root of the sum of squares of the rms values of individual vectors, meaning as

$$\|\mathbf{x} + \mathbf{y}\| = \sqrt{\|\mathbf{x}\|^2 + \|\mathbf{y}\|^2} \quad (\text{B4})$$

only if the scalar product of these vectors is equal to zero, i.e.,

$$(\mathbf{x}, \mathbf{y}) = 0$$

meaning if they are mutually orthogonal.

When three-phase quantities are expressed in terms of their crms values, namely

$$\mathbf{x} = \sqrt{2} \operatorname{Re}\{X e^{j\omega t}\}, \quad \mathbf{y} = \sqrt{2} \operatorname{Re}\{Y e^{j\omega t}\}.$$

then their scalar product is equal to

$$\begin{aligned} (\mathbf{x}, \mathbf{y}) &= \frac{1}{T} \int_0^T \mathbf{x}^T(t) \mathbf{y}(t) dt = \\ &= \frac{2}{T} \int_0^T \operatorname{Re}\{X^T e^{j\omega t}\} \operatorname{Re}\{Y e^{j\omega t}\} dt = \\ &= \operatorname{Re} X^T \operatorname{Re} Y + \operatorname{Im} X^T \operatorname{Im} Y = \operatorname{Re}\{X^T Y^*\}. \end{aligned} \quad (\text{B5})$$

Let us calculate scalar products of three-phase quantities of a positive sequence  $\mathbf{x}^p(t)$ , of negative sequence  $\mathbf{y}^n(t)$  and zero sequence  $\mathbf{w}^z(t)$ ,

$$\begin{aligned} \mathbf{x}^p(t) &= \sqrt{2} \operatorname{Re}\{\mathbf{1}^p X_R e^{j\omega t}\} \\ \mathbf{y}^n(t) &= \sqrt{2} \operatorname{Re}\{\mathbf{1}^n Y_R e^{j\omega t}\} \\ \mathbf{w}^z(t) &= \sqrt{2} \operatorname{Re}\{\mathbf{1}^z W_R e^{j\omega t}\}. \end{aligned}$$

These scalar products are equal to, respectively

$$\begin{aligned} (\mathbf{x}^p, \mathbf{y}^n) &= \operatorname{Re}\{(\mathbf{1}^{pT} X_R)(\mathbf{1}^n Y_R)^*\} = \operatorname{Re}\{\mathbf{1}^{pT} \mathbf{1}^{n*} X_R Y_R^*\} = \\ &= \operatorname{Re}\left\{[1, \alpha^*, \alpha] \begin{bmatrix} 1 \\ \alpha^* \\ \alpha \end{bmatrix} X_R Y_R^*\right\} = \operatorname{Re}\{[1 + \alpha + \alpha^*] X_R Y_R^*\} = 0. \end{aligned} \quad (\text{B6})$$

$$\begin{aligned} (\mathbf{x}^p, \mathbf{w}^z) &= \operatorname{Re}\{(\mathbf{1}^{pT} X_R)(\mathbf{1}^z W_R)^*\} = \operatorname{Re}\{\mathbf{1}^{pT} \mathbf{1}^{z*} X_R W_R^*\} = \\ &= \operatorname{Re}\left\{[1, \alpha^*, \alpha] \begin{bmatrix} 1 \\ 1 \\ 1 \end{bmatrix} X_R W_R^*\right\} = \operatorname{Re}\{[1 + \alpha^* + \alpha] X_R W_R^*\} = 0. \end{aligned} \quad (\text{B7})$$

$$\begin{aligned} (\mathbf{y}^n, \mathbf{w}^z) &= \operatorname{Re}\{(\mathbf{1}^{nT} Y_R)(\mathbf{1}^z W_R)^*\} = \operatorname{Re}\{\mathbf{1}^{nT} \mathbf{1}^{z*} Y_R W_R^*\} = \\ &= \operatorname{Re}\left\{[1, \alpha, \alpha^*] \begin{bmatrix} 1 \\ 1 \\ 1 \end{bmatrix} Y_R W_R^*\right\} = \operatorname{Re}\{[1 + \alpha + \alpha^*] Y_R W_R^*\} = 0. \end{aligned} \quad (\text{B8})$$

Thus, three-phase symmetrical quantities of different sequences are mutually orthogonal.

In the current decomposition

$$\mathbf{i} = \mathbf{i}_a + \mathbf{i}_r + \mathbf{i}_u^n + \mathbf{i}_u^z \quad (\text{B9})$$

the active and reactive currents are of positive sequence, thus they are orthogonal to both unbalanced currents. Let us check orthogonality of the active and reactive currents:

$$\begin{aligned} (\mathbf{i}_a, \mathbf{i}_r) &= \operatorname{Re}\{(G_e \mathbf{1}^p U_R)(jB_e \mathbf{1}^p U_R)^*\} = \operatorname{Re}\{\mathbf{1}^{pT} \mathbf{1}^{p*} (-jB_e G_e U_R^2)\} = \\ &= \operatorname{Re}\left\{[1, \alpha^*, \alpha] \begin{bmatrix} 1 \\ \alpha \\ \alpha^* \end{bmatrix} (-jB_e G_e U_R^2)\right\} = \operatorname{Re}\{3(-jB_e G_e U_R^2)\} = 0. \end{aligned} \quad (\text{B10})$$

It means that scalar products of all components in decomposition (B9)

$$(\mathbf{i}_a, \mathbf{i}_r), (\mathbf{i}_a, \mathbf{i}_u^n), (\mathbf{i}_a, \mathbf{i}_u^z), (\mathbf{i}_r, \mathbf{i}_u^n), (\mathbf{i}_r, \mathbf{i}_u^z), (\mathbf{i}_u^n, \mathbf{i}_u^z)$$

are equal to zero, thus these components are mutually orthogonal.

## BIOGRAPHIES



**Leszek S. Czarnecki**, IEEE Life Fellow, Alfredo M. Lopez Distinguished Professor at Louisiana State Univ., Titled Professor of Technical Sciences of Poland. He received the M.Sc. and Ph.D. degrees in electrical engineering and Habil. Ph.D. degree from the Silesian Univ. of Technology, Poland, in 1963, 1969 and 1984, respectively, where he was employed as an Assistant Professor. Beginning in 1984 he worked for two years at the Power Engineering Section, Division of Electrical Engineering, National Research Council (NRC) of Canada as a Research Officer. In 1987 he joined the Electrical Engineering Dept. at Zielona Gora University of Technology, Poland. In 1989 Dr. Czarnecki joined the Electrical and Computer Engineering Department of Louisiana State University, Baton Rouge, where he is a Professor of Electrical Engineering now. For developing a power theory of three-phase nonsinusoidal unbalanced systems and methods of compensation of such systems he was elected to the grade of Fellow IEEE in 1996. His research interests include network analysis and synthesis, power phenomena in nonsinusoidal systems, compensation. Decorated by the President of Poland with the Knight Cross of the Medal of Merit of the Republic of Poland for the contribution in the United States to Poland acceptance in NATO. (School of Electrical Engineering and Comp. Science, Louisiana State University, Baton Rouge, 824 Louray Dr. LA 70808, Phone: 225 767 6528, [lsczar@cox.com](mailto:lsczar@cox.com), [www.lsczar.info](http://www.lsczar.info)).



**Paul M. Haley** was born in Anchorage, Alaska. He received the M.S. Degree in Electrical Engineering from Louisiana State University in 2012. He is now an Electrical Engineering Ph.D. student at Louisiana State University and a recipient of the Louisiana State Board of Regents Fellowship. His current research interests include power theory and compensation in power systems with asymmetrical and distorted voltages and currents. (School of Electrical Eng. and Computer Science, Louisiana State University, Baton Rouge, LA 70803, USA, Phone: 504-201-2578, email: [pahaley06@hotmail.com](mailto:pahaley06@hotmail.com)).